

ESHV30

Dual AV Wall Shelf with Glass for AV Components

Flat panel display home theatre systems often encounter issues when it comes to displaying audio visual components that will match the stylistic qualities of the mount. This dual AV Wall Shelf solves the problem by giving consumers the ability to center their audio visual components in a low-profile manner. The shelving unit provides a sleek and stylish opportunity for consumers to organize their DVD/Blu-ray® players, cable/satellite boxes and game consoles in a way that suits the style of their home. It incorporates cable management for a clean appearance.



Max load: 30lb (13.6kg) per shelf

FEATURES

- Strong, tempered glass shelves can be vertically adjusted to accommodate AV components of any height
- Cable management system helps keep cables concealed and organized
- Supports up to 30lb per shelf
- Bubble level makes for a quick and easy installation

■ ADJUSTABLE HEIGHT

Easily adjust the height of the component shelf after installation without the use of tools

■ BUBBLE LEVEL

For a quick and easy installation without the use of extra tools



■ TEMPERED GLASS SHELVES

For up to 30lb of support* with a sleek, modern look

* per shelf

■ CABLE MANAGEMENT

Keeps component cables concealed and organized



Side View



RoHS

CLICK: www.peerless-av.com

CALL: 800.865.2112

FAX: 800.359.6500

peerless-AV™

Model Numbers

WARRANTY: Limited 5-year

ESHV30 Dual AV Wall Shelf with Glass for AV Components

Product Specifications

	DIMENSIONS (W x H x D)	PRODUCT WEIGHT	LOAD CAPACITY	FINISH	AVAILABLE COLORS
ESHV30	15.6" x 25.44" x 13.76" (396 x 646 x 350mm)	8.96lb (4.06kg)	30lb (13.6kg) per shelf	Powder coat	Gloss Black

Package Specifications

	PACKAGE SIZE (W x H x D)	PACKAGE SHIP WEIGHT	PACKAGE UPC CODE	PACKAGE CONTENTS	UNITS IN PACKAGE
ESHV30	13.25" x 2.625" x 17.125" (337 x 67 x 435mm)	10.5lb (4.76kg)	735029276104	Dual AV Wall Shelves with Glass, Instructions, Installation hardware	1

All dimensions = inch (mm)

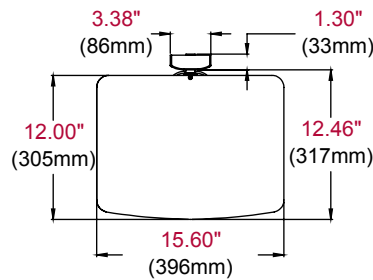

TOP VIEW

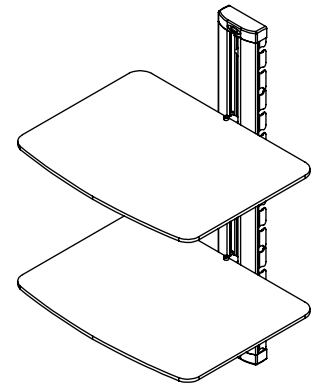

ISOMETRIC VIEW

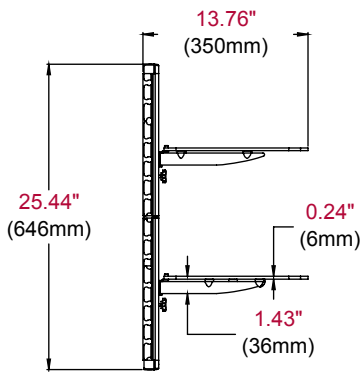

SIDE VIEW

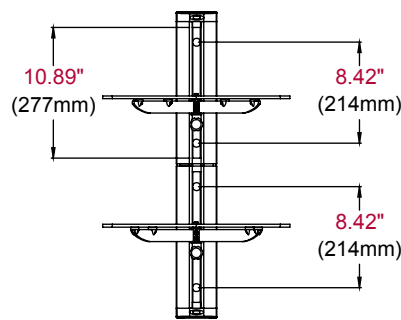

FRONT VIEW

ARCHITECTS SPECIFICATIONS

The Peerless-AV Dual AV Wall Shelf with Glass shall be model ESHV30.
Assembly and installation shall be done according to instructions provided by the manufacturer.



PRESENCE
www.presence.qc.ca
418.681.2470

Peerless Industries, Inc. ■ 2300 White Oak Circle ■ Aurora, IL 60502 ■ (800) 865-2112 ■ (630) 375-5100 ■ Fax: (800) 359-6500 ■ www.peerless-av.com

Visit www.peerless-av.com to see the complete line of AV solutions from Peerless-AV, including flat panel mounts, projector mounts, carts/stands, furniture, cables, screen cleaners and a full assortment of accessories.