

SR560M
SR560M-AB
SR560M-AW



Display size
32"-75"



Max load
150lb (68.2kg)
display
10lb (4.55kg)
per shelf

Additional Features

- ✓ Display and component shelf can be located anywhere along the column for perfect component placement and viewing height (up to 60" at center)
- ✓ Integrated cable management protects, contains and conceals cables for a clean, professional installation
- ✓ Maneuvers easily on 4" (102mm) swivel casters, two locking
- ✓ Pre-assembled base provides rigidity, stability and quick assembly
- ✓ Textured black powder coat finish helps hide finger prints and dust
- ✓ Open frame display adaptor helps prevent display input interference
- ✓ Universal mount fits displays with mounting patterns from 200 x 200mm up to 600 x 400mm

Flat Panel Cart

FOR 32" TO 75" DISPLAYS

The SR560M Flat Panel Cart has been redesigned to include all of the features you may need, making it perfect for any application. Mobility, appealing design, display height adjustment, pre-assembled base and UL® certification ensure quick assembly while providing a ridged, but attractive, structure that fits into any décor. The 4" castors make it easy to move from room to room while the UL® certification ensures you that it can be done with safety in mind.

Designed to meet UL certifications, the SR560M incorporates safety and security, ensuring you get the job done correctly.



■ **PLUMB ADJUSTMENT**
5 degrees of negative adjustment keeps even the heaviest of displays level

■ **UL/CUL CERTIFIED**
Provides the highest level of safety

■ **COMPONENT PLACEMENT**
Metal shelf can be located anywhere along the column assembly

■ **OPEN FRAME ADAPTOR**
Helps prevent display input interference

■ **VERTICAL ADJUSTMENT**
Display and component shelf can be located anywhere along the column (up to 60" at center)

■ **WELDED BASE**
Provides rigidity, stability and quick assembly

■ **SAFE AND EASY MANEUVERABILITY**
4" (102mm) swivel casters meet UL/CUL requirements

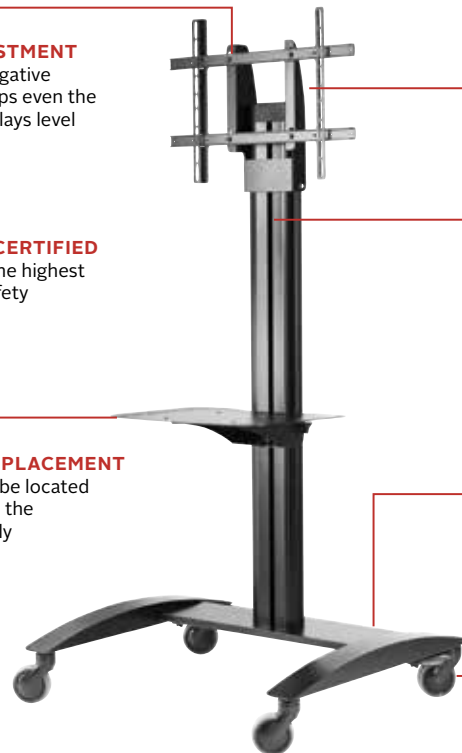

*Antimicrobial protection is limited to the treated article and does not protect a user against disease causing bacteria. Always clean products thoroughly after each use. Visit agion-tech.com for more details.



RoHS



SR560M-AB/AW:



Cable management allows cables to enter or exit anywhere along the column

info@peerless-av.com
peerless-av.com

peerless-AV®

SR560M(-AB)(-AW) Flat Panel Cart for 32" to 75" Displays

Product Specifications

	DIMENSIONS (W X H X D)	PRODUCT WEIGHT	LOAD CAPACITY	FINISH	AVAILABLE COLORS
SR560M(-AB)(-AW)	34.95" x 68.38" x 29.00" (888 x 1736 x 737mm)	66lb (30kg)	150lb (68.2kg) display 10lb (4.55kg) per shelf	Textured Powder Coat	SR560M: Black SR560M-AB: Antimicrobial* Black SR560M-AW: Antimicrobial* White

Package Specifications

*Antimicrobial protection is limited to the treated article and does not protect a user against disease causing bacteria. Always clean products thoroughly after each use. Visit agion-tech.com for more details.

	PACKAGE SIZE (W x H x D)	PACKAGE SHIP WEIGHT	PACKAGE UPC CODE	PACKAGE CONTENTS	UNITS IN PACKAGE
SR560M(-AB)(-AW)	47.50" x 7.25" x 38.50" (1207 x 184 x 978mm)	79lb (35.9kg)	SR560M: 735029247715 SR560M-AB: 735029281771 SR560M-AW: 735029281788	Assembled base, Aluminum column, Universal display adaptor, Metal component shelf, (2) swivel casters, (2) locking swivel casters, hardware & instructions	1

Accessories

- ACC310:** Feet Accessory
- ACC316:** Safety Belt
- ACC320:** Electrical Outlet Strip with Cord Wrap
- ACC-BPR:** Bumper Accessory for legs
- ACC-GS1:** Tempered Glass Shelf
- ACC-LA:** Laptop Arm
- ACC-MS:** Metal Shelf
- ACC-VCS:** Video Conferencing Shelf
- DSX750:** Media Player Storage

All dimensions = inch (mm)

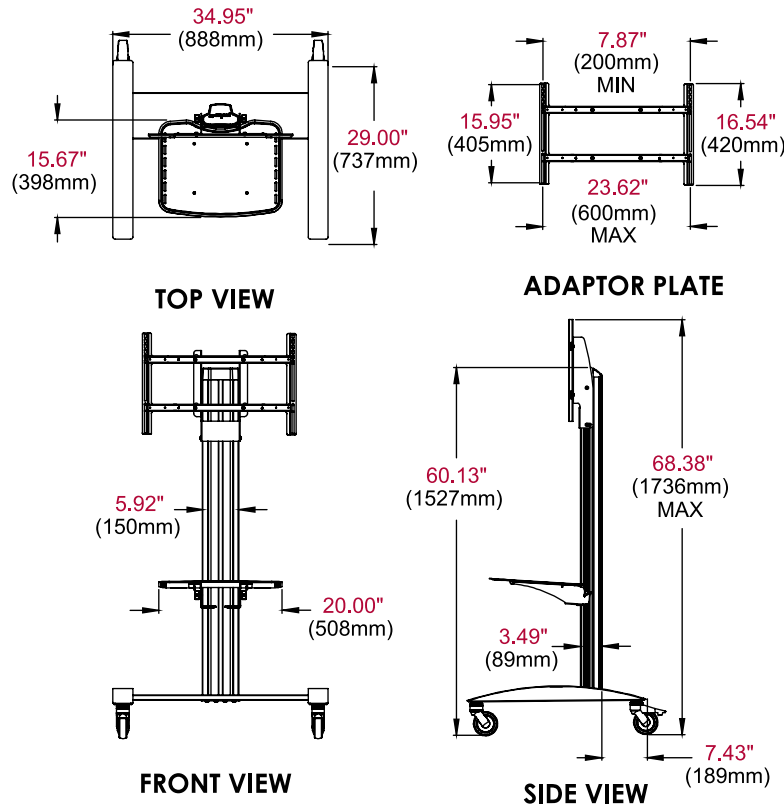

Architect Specifications

The Flat Panel Cart shall be a Peerless-AV model SR560M(-AB)(-AW) and shall be located where indicated on the plans. Assembly and installation shall be done according to instructions provided by the manufacturer.

Visit peerless-av.com to see the complete line of AV solutions from Peerless-AV, including outdoor displays, wireless, kiosks, digital audio, display mounts, projector mounts, carts/stands, and a full assortment of accessories.

Peerless-AV
2300 White Oak Circle
Aurora, IL 60502 USA
(800) 865-2112
(630) 375-5100
Fax: (800) 359-6500

Peerless-AV Europe
Unit 3 Watford Interchange
Colonial Way, Watford
Herts, WD24 4WP
United Kingdom
+44 (0) 1923 200100
Fax: +44 (0) 1923 200101

Peerless-AV de México
Ave de las Industrias 413
Parque Industrial Escobedo
Escobedo, N.L.,
Mexico 66050
+52 (81) 8384-8300
Fax: +52 (81) 8384-8360

