

## Key Features

- Integrated ViewBoard on-screen control for better lesson delivery
- Motorized height adjustment for easy and fast access to ViewBoard
- Accessible design with large wheels for maximum mobility
- Smart space design to keep all cables and accessories organized
- Safety-centric features for secure learning environment



## Product Description

The VB-STND-007 motorized trolley cart securely accommodates ViewSonic 55", 65", 75", and 86" ViewBoard interactive flat panel displays, or any similar displays weighing up to 75 kg. Thanks to integrated on-screen control, the trolley's height can be easily adjusted using the ViewBoard app toolbar without class interruption. Designed for safety and equipped with 360-directional quiet wheels, this mobile cart lets you securely and silently move the ViewBoard display from room to room for easy sharing of resources.

## ERGONOMICS

Swivel: 360

Height Adjust: 560mm

## WALL MOUNT BRACKET

up to 800x600mm

## MATERIAL

Aluminum Alloy, Plastic, Steel

## LOADING

Wall mount: 75 kg max. / 165 lb max.

Plate: 10 kg max. / 22 lb max.

## DIMENSIONS

Physical (WxHxD): 1248.9x(1330.7~1890.7)x716 (mm) / 49.17x(52.4~74.44)x28.19 (in)

Packaging (WxHxD): 1150x490x1010 (mm) / 45.28x19.29x39.77 (in)

## WEIGHT

Net: 64 kg / 141 lb

Gross: 73.3 kg / 161.6 lb

## COMPLIANCE

cTUVus, FCC, Mexican(NOM), UL1678, CE, CB, RoHS, ErP, REACH, WEEE, RCM

## INBOX ITEMS

1. Control Pad
2. Power Cord
3. Power Adapter Cord
4. USB Adapter Cable
5. Screw Bag
6. Core Hook(x2)
7. Quick Start Guide
8. Compliance statement

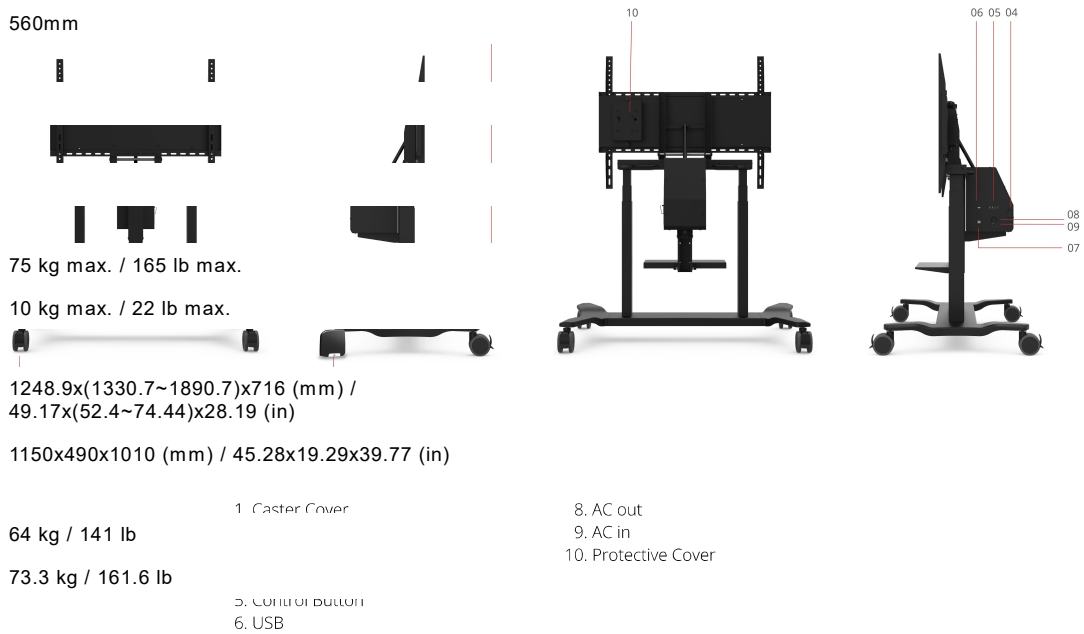

viewsonic.com