

Kramer Electronics, Ltd.



USER MANUAL

Model:

VP-4x4

4x4 VGA/XGA Audio Matrix Switcher

Contents

1	Introduction	1
2	Getting Started	1
2.1	Quick Start	1
3	Overview	3
4	Your VGA/XGA Audio Matrix Switcher	3
5	Installing the VP-4x4 on a Rack	7
6	Connecting the VP-4x4 4x4 VGA XGA Audio Matrix Switcher	8
6.1	Connecting the VP-4x4 Rear Panel	8
6.2	Connecting the Balanced/Unbalanced Stereo Audio Input/Output	10
6.3	Connecting a PC	11
6.4	Cascading Machines	11
6.4.1	Dipswitch Settings	13
7	Operating Your Audio Matrix Switcher	14
7.1	Displaying Unit Characteristics	14
7.2	Choosing the Audio-Follow-Video or Breakaway Option	14
7.2.1	Setting the Audio-Follow-Video Option	15
7.2.2	Setting the Breakaway Option	15
7.3	Switching OUT-IN Combinations	15
7.4	Confirming Settings	16
7.4.1	Toggling between the AT ONCE and CONFIRM Modes	16
7.4.2	Confirming a Switching Action	17
7.5	Storing/Recalling Input/Output Configurations	17
7.5.1	Storing an Input/Output Configuration	17
7.5.2	Recalling an Input/Output Configuration	18
7.5.3	Deleting an Input/Output Configuration	18
7.6	Locking the Front Panel	18
8	Technical Specifications	19
9	Table of Hex Codes for Serial Communication	20
10	Kramer Protocol 2000	21

Figures

Figure 1: VP-4x4 VGA/XGA Audio Matrix Switcher	4
Figure 2: Connecting the VP-4x4 VGA/XGA Audio Matrix Switcher	9
Figure 3: Connecting the Balanced Stereo Audio Input/Output	10
Figure 4: Connecting the Unbalanced Stereo Audio Output	10
Figure 5: Connecting an Unbalanced Source to the Balanced Input	10
Figure 6: Connecting a PC without using a Null-modem Adapter	11
Figure 7: Control Configuration via RS-232 and RS-485	12
Figure 8: VP-4x4 Dipswitches	13
Figure 9: VP-4x4 Unit Characteristics	14
Figure 10: SELECTOR Buttons	17

Tables

Table 1: Front Panel VP-4x4 VGA/XGA Audio Matrix Switcher Features	5
Table 2: Rear Panel VP-4x4 VGA/XGA Audio Matrix Switcher Features	6
Table 3: Dipswitch Settings	13
Table 4: Machine # Dipswitch Settings	13
Table 5: Technical Specifications of the VP-4x4 VGA/XGA Audio Matrix Switcher	19
Table 6: VP-4x4 Hex Codes for Switching via RS-232/RS-485	20
Table 7: VP-4x4 Hex Codes for Switching Audio Channels via RS-232/RS-485	20
Table 8: Protocol Definitions	21
Table 9: Instruction Codes for Protocol 2000	22

1 Introduction

Welcome to Kramer Electronics (since 1981): a world of unique, creative and affordable solutions to the infinite range of problems that confront the video, audio and presentation professional on a daily basis. In recent years, we have redesigned and upgraded most of our line, making the best even better! Our 500-plus different models now appear in 8 Groups¹, which are clearly defined by function.

Congratulations on purchasing your Kramer **VP-4x4 VGA/XGA Audio Matrix Switcher**. This product is ideal for the following typical applications:

- Professional display systems requiring true 4x4 matrix operation
- Multimedia and presentation source and acceptor selection
- Remote monitoring of computer activity in schools and businesses
- Rental/staging applications

The package includes the following items:

- **VP-4x4 VGA/XGA Audio Matrix Switcher**
- Windows®-based Kramer control software²
- Null-modem adapter
- Power cord³ and this user manual⁴

2 Getting Started

We recommend that you:

- Unpack the equipment carefully and save the original box and packaging materials for possible future shipment
- Review the contents of this user manual
- Use Kramer high performance high resolution cables⁵

2.1 Quick Start

This quick start chart summarizes the basic setup and operation steps.

1 GROUP 1: Distribution Amplifiers; GROUP 2: Video and Audio Switchers, Matrix Switchers and Controllers; GROUP 3: Video, Audio, VGA/XGA Processors; GROUP 4: Interfaces and Sync Processors; GROUP 5: Twisted Pair Interfaces; GROUP 6: Accessories and Rack Adapters; GROUP 7: Scan Converters and Sealers; and GROUP 8: Cables and Connectors

2 Download the latest software from our Web site at <http://www.kramerelectronics.com>

3 We recommend that you use only the power cord that is supplied with this machine

4 Download up-to-date Kramer user manuals from our Web site at <http://www.kramerelectronics.com>

5 The complete list of Kramer cables is on our Web site at <http://www.kramerelectronics.com>

Step 1: Mount the machine - see section 5

Mount the machine in a rack or stick the 4 rubber feet to the underside

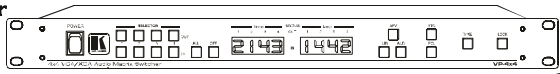

Step 2: Connect the inputs and outputs - see section 6

Connect the video inputs and outputs



Connect the audio inputs and outputs



Step 3: Configure the VP-4x4 - see section 6

CONNECT A SINGLE MACHINE

Set the Machine # to 1

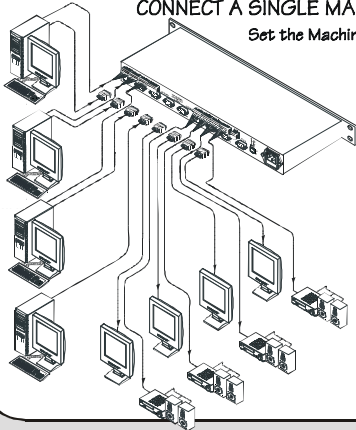

CASCADE MACHINES

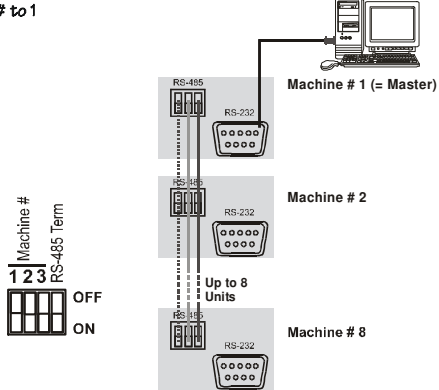

Step 4: Turn the power ON

Step 5: Operate the machine - see section 7

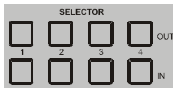

Use the SELECTOR buttons to switch the inputs to the outputs



A-V - Audio follows video when switching
 VID - Switching relates to the video signal
 AUD - Switching relates to the audio signal

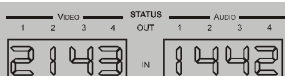

Read the VIDEO and the AUDIO STATUS on the 7-segment display



Connect a selected input to ALL the outputs; disconnect an output (OFF) from an input, or disconnect all the outputs (ALL + OFF)



Press TAKE to confirm actions



Store (STO) and recall (RCL) actions



LOCK the front panel

Operate via the front panel buttons, RS-232 and RS-485

3 Overview

The **VP-4x4** is a true 4x4 matrix switcher for computer graphics (VGA/XGA) signals and balanced stereo audio signals. The **VP-4x4** enables the user to simultaneously route any or all of the four inputs to any or all of the four outputs.

In addition, the **VP-4x4** includes:

- A video bandwidth of 440MHz that ensures transparent VGA/XGA performance
- Easy-to-connect detachable terminal block connectors on which the audio signals reside
- DC coupled inputs and outputs
- Audio-follow-video and breakaway options
- Storing and recalling setup options
- A TAKE button for precise switch control that lets you execute multiple switches all at once
- A LOCK button to prevent tampering with the front panel

Control the **VP-4x4** using the front panel buttons, or remotely via RS-485 or RS-232 serial commands transmitted by a touch screen system, PC, or other serial controller (including the Kramer **RC-IR1** external remote receiver).

To achieve the best performance:

- Connect only good quality connection cables, thus avoiding interference, deterioration in signal quality due to poor matching, and elevated noise levels (often associated with low quality cables)
- Avoid interference from neighboring electrical appliances that may adversely influence signal quality and position your Kramer **VP-4x4** away from moisture, excessive sunlight and dust

4 Your VGA/XGA Audio Matrix Switcher

Figure 1 illustrates the front and rear panels of the **VP-4x4**. Table 1 and Table 2 define the front and rear panels of the **VP-4x4**, respectively.

Your VGA/XGA Audio Matrix Switcher

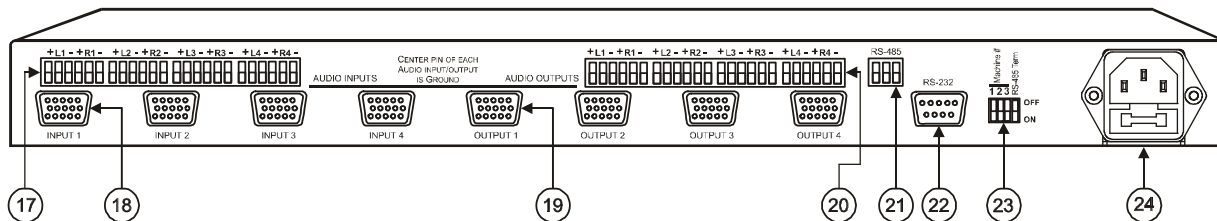
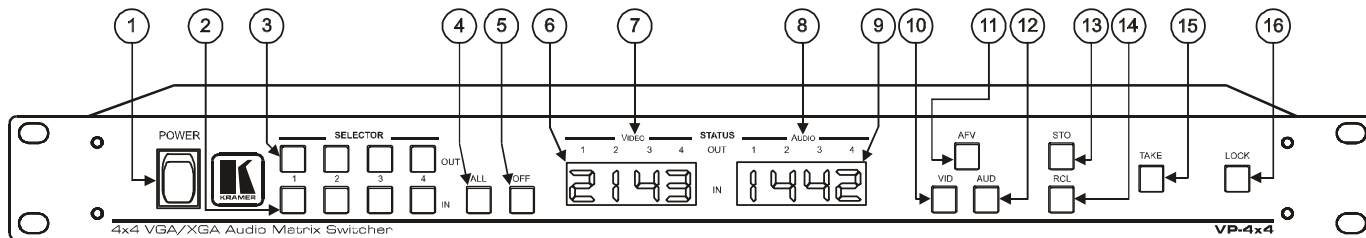

Figure 1: VP-4x4 VGA/XGA Audio Matrix Switcher

Your VGA/XGA Audio Matrix Switcher

Table 1: Front Panel VP-4x4 VGA/XGA Audio Matrix Switcher Features

#	Feature		Function
1	Power Switch		Illuminated switch for turning the unit ON or OFF
2	SELECTOR IN Buttons		Select the input to switch to the output ¹
3	SELECTOR OUT Buttons		Select the output to which the input is switched
4	ALL Button		Pressing ALL before pressing an input button, connects that input to all outputs ²
5	OFF Button		Pressing OFF after pressing an output button disconnects that output from the inputs. To disconnect all the outputs, press the ALL button and then the OFF button
6	STATUS	VIDEO IN STATUS 7-segment Display	Displays the selected video input switched to the output (marked above each input). Also displays the number of IN and OUT ports ³
7		STATUS OUT labels	Identifies a cross point between each video output to which the video input displayed below it is connected
8		AUDIO STATUS OUT labels	Identifies a cross point between each audio output to which the audio input displayed below it is connected
9		IN STATUS 7-segment Display	Displays the selected audio input switched to the output (marked above each input). Also displays the firmware version number and the MACHINE # ³
10	VID Button		When pressed ⁴ actions relate to video
11	AFV Button		When pressed, the audio channels follow the video channels. The button is illuminated when the AFV mode is selected
12	AUD Button		When pressed ⁵ actions relate to audio
13	STO Button		Pressing STO (STORE) followed by an output button stores the current setting ⁶
14	RCL Button		Pressing the RCL (RECALL) button and the corresponding OUTPUT key recalls a setup. The stored status blinks. Pressing a different OUTPUT button lets you view ⁷ another setup. After making your choice, pressing the RCL button again implements the new status
15	TAKE Button		Pressing TAKE toggles the mode between the CONFIRM mode ⁸ and the AT ONCE mode (user confirmation per action is unnecessary)
16	LOCK Button		Disengages the front panel switches

1 The SELECTOR IN and OUT buttons also store/recall the input/output configurations (see section 7.5)

2 For example, press ALL and then Input button # 2 to connect input # 2 to all the outputs

3 Refer to section 7.1

4 The VID button is illuminated when in breakaway mode and actions relate to video

5 The AUD button is illuminated when in breakaway mode and actions relate to audio

6 For example, press STO and then the Output button # 3 to store in Setup # 3

7 Only view, nothing is implemented at this stage

8 When in the CONFIRM mode, the TAKE button illuminates

Your VGA/XGA Audio Matrix Switcher

Table 2: Rear Panel VP-4x4 VGA/XGA Audio Matrix Switcher Features

#	Feature	Function
17	<i>AUDIO INPUTS</i> Terminal Block Connectors	Connect to the balanced stereo audio sources (from 1 to 4)
18	INPUT HD15F Connectors	Connects to the VGA/XGA video sources (from 1 to 4)
19	OUTPUT HD15F Connectors	Connects to the VGA/XGA video acceptors (from 1 to 4)
20	<i>AUDIO OUTPUTS</i> Terminal Block Connectors	Connect to the balanced stereo audio acceptors (from 1 to 4)
21	<i>RS-485</i> Terminal Block Port	Pins B (-) and A (+) are for RS-485; Pin G (Ground) may be connected to the shield of the cable if desired (see the PINOUT in Figure 7)
22	<i>RS-232</i> DB 9F Port	Connects to the PC or the Remote Controller
23	Setup Dipswitches	Dipswitches for setup of the unit (DIP 1, DIP 2 and DIP 3 are for setting the machine #; DIP 4 is for RS-485 Termination)
24	Power Connector with Fuse	AC connector enabling power supply to the unit

5 Installing the VP-4x4 on a Rack

This section describes what to do before installing on a rack and how to rack mount.

Before Installing on a Rack

Before installing on a rack, be sure that the environment is within the recommended range:	
Operating temperature range	+5 to +45 Deg. Centigrade
Operating humidity range	5 to 65 % RHL, non-condensing
Storage temperature range	-20 to +70 Deg. Centigrade
Storage humidity range	5 to 95% RHL, non-condensing



CAUTION!!

When installing on a 19" rack, avoid hazards by taking care that:

- 1 It is located within the recommended environmental conditions, as the operating ambient temperature of a closed or multi unit rack assembly may exceed the room ambient temperature.
- 2 Once rack mounted, enough air will still flow around the machine.
- 3 The machine is placed straight in the correct horizontal position.
- 4 You do not overload the circuit(s). When connecting the machine to the supply circuit, overloading the circuits might have a detrimental effect on overcurrent protection and supply wiring. Refer to the appropriate nameplate ratings for information. For example, for fuse replacement, see the value printed on the product label.
- 5 The machine is earthed (grounded) in a reliable way and is connected only to an electricity socket with grounding. Pay particular attention to supply connections other than direct connections to the branch circuit (for example, the use of power strips), and that you use only the power cord that is supplied with the machine.

How to Rack Mount

To rack-mount the machine:

- 1 Attach both ear brackets to the machine. To do so, remove the screws from each side of the machine (3 on each side), and replace those screws through the ear brackets.

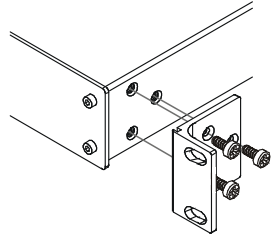

- 2 Place the ears of the machine against the rack rails, and insert the proper screws (not provided) through each of the four holes in the rack ears.

Note that:

- In some models, the front panel may feature built-in rack ears
- Detachable rack ears can be removed for desktop use
- Always mount the machine in the rack before you attach any cables or connect the machine to the power
- If you are using a Kramer rack adapter kit (for a machine that is not 19"), see the Rack Adapters user manual for installation instructions (you can download it at: <http://www.kramerelectronics.com>)

6 Connecting the VP-4x4 4x4 VGA XGA Audio Matrix Switcher

This section describes how to:

- Connect the **VP-4x4** rear panel (see section 6.1)
- Connect a balanced stereo audio input/output (see section 6.2)
- Connect the **VP-4x4** to a controlling device via RS-232 (see section 6.3)
- Connect several **VP-4x4** machines (see section 6.4)
- Set the dipswitches (see section 6.4.1)

6.1 Connecting the VP-4x4 Rear Panel

To connect¹ the **VP-4x4**, as illustrated in the example in Figure 2, do the following²:

1. Connect up to four VGA/XGA computer graphics sources to the HD15F INPUT connectors (from INPUT 1 to INPUT 4).
2. Connect up to four balanced³ stereo audio sources (for example, the Computer's audio source⁴) to the AUDIO INPUT terminal block connectors (from 1 to 4).
3. Connect the four OUTPUT connectors to up to four VGA/XGA video acceptors (for example, displays).
4. Connect the four AUDIO OUTPUT terminal block connectors to up to four balanced stereo audio acceptors³ (for example, balanced stereo audio amplifiers with speakers)
5. Set the dipswitches (see section 6.4.1).
6. As an option, you can connect a PC and/or controller to the RS-232 port (see section 6.3) and the RS-485 port (see section 6.4)
7. Connect the power cord⁵.

1 You do not need to connect all inputs and outputs

2 Switch OFF the power on each device before connecting it to your VP-4x4. After connecting your VP-4x4, switch on its power and then switch on the power on each device

3 See section 6.2

4 Alternatively, you can connect a separate audio source, or no source at all

5 We recommend that you use only the power cord that is supplied with this machine

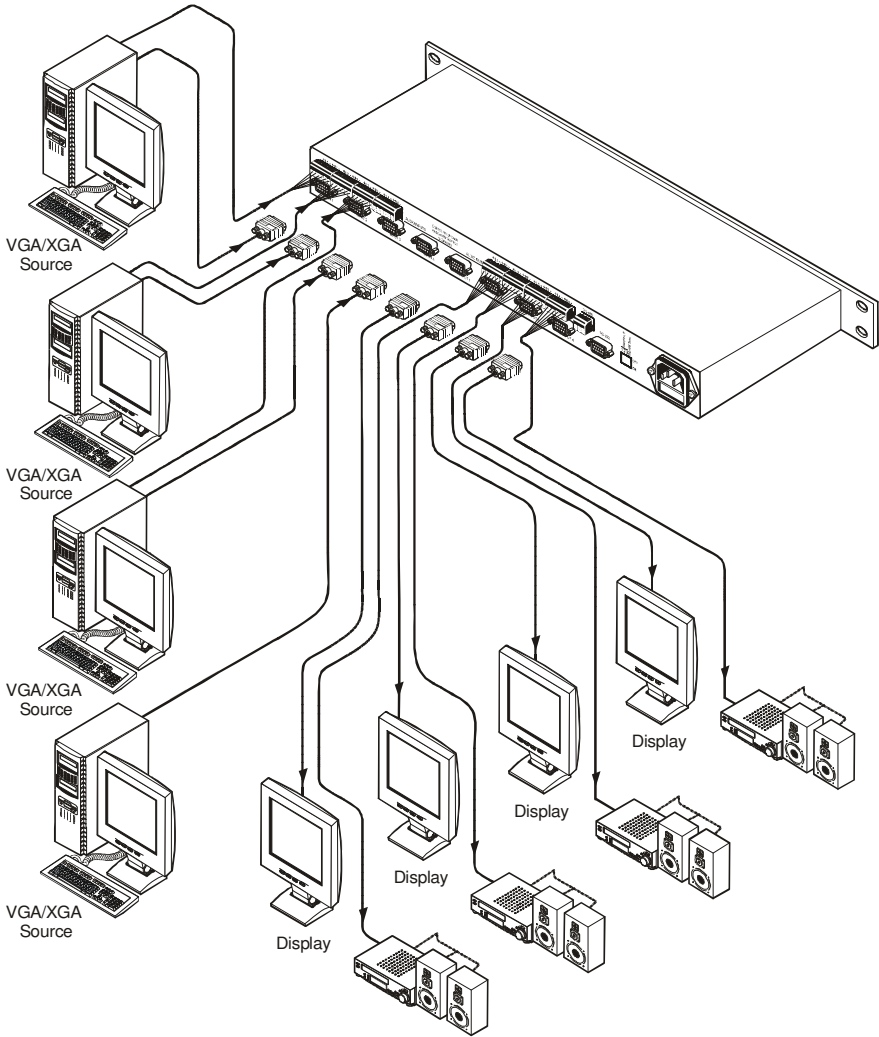

Figure 2: Connecting the VP-4x4 VGA/XGA Audio Matrix Switcher

6.2 Connecting the Balanced/Unbalanced Stereo Audio Input/Output

This section illustrates how to wire:

- A balanced input/output connection (see Figure 3)
- An unbalanced audio output (see Figure 4)
- An unbalanced source to the balanced input on the **VP-4x4** (see Figure 5)

Figure 3 illustrates how to wire a balanced input/output connection (for example, audio INPUT 1 or AUDIO OUTPUT 1):

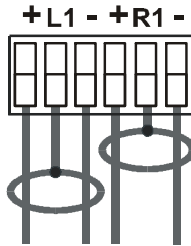

Figure 3: Connecting the Balanced Stereo Audio Input/Output

Figure 4 illustrates how to wire an unbalanced acceptor to the balanced output of the unit (for example, AUDIO OUTPUT 1):

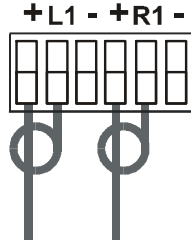

Figure 4: Connecting the Unbalanced Stereo Audio Output

Figure 5 illustrates how to connect an unbalanced source to the balanced input on the **VP-4x4** (for example, AUDIO INPUT 1):

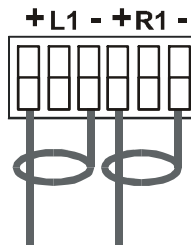

Figure 5: Connecting an Unbalanced Source to the Balanced Input

6.3 Connecting a PC

To connect a PC to the **VP-4x4** unit, using the Null-modem adapter provided with the machine (recommended):

- Connect the RS-232 DB9 rear panel port on the Master **VP-4x4** unit to the Null-modem adapter and connect the Null-modem adapter with a 9-wire flat cable to the RS-232 DB9 port on your PC

To connect a PC to the **VP-4x4** unit, without using a Null-modem adapter:

- Connect the RS-232 DB9 port on your PC to the RS-232 DB9 rear panel port on the Master **VP-4x4** unit, as Figure 6 illustrates

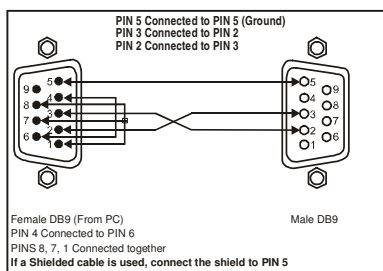

Figure 6: Connecting a PC without using a Null-modem Adapter

6.4 Cascading Machines

You can cascade up to eight **VP-4x4** units with control from a PC or serial controller.

To cascade up to eight individual **VP-4x4** units via RS-485, as illustrated in the example in Figure 7, do the following:

1. Connect the sources and acceptors (see section 6.1).
2. Connect the RS-232 port of the first **VP-4x4** unit to a PC using the Null-modem adapter provided with the machine (see section 6.3).
3. Connect the RS-485 terminal block port on the first unit to the RS-485 port on the second **VP-4x4** unit and so on, connecting all the RS-485 ports.
4. Set the dipswitches, as section 6.4.1 describes:
 - Set the first **VP-4x4** unit as Machine # 1 and the following seven **VP-4x4** units as Machine # 2 to Machine # 8, according to Table 4
 - Set DIP 4 ON on the first and last **VP-4x4** units (terminating the RS-485 line at 120Ω). Set DIP 4 OFF on the other **VP-4x4** units

Connecting the VP-4x4 4x4 VGA XGA Audio Matrix Switcher

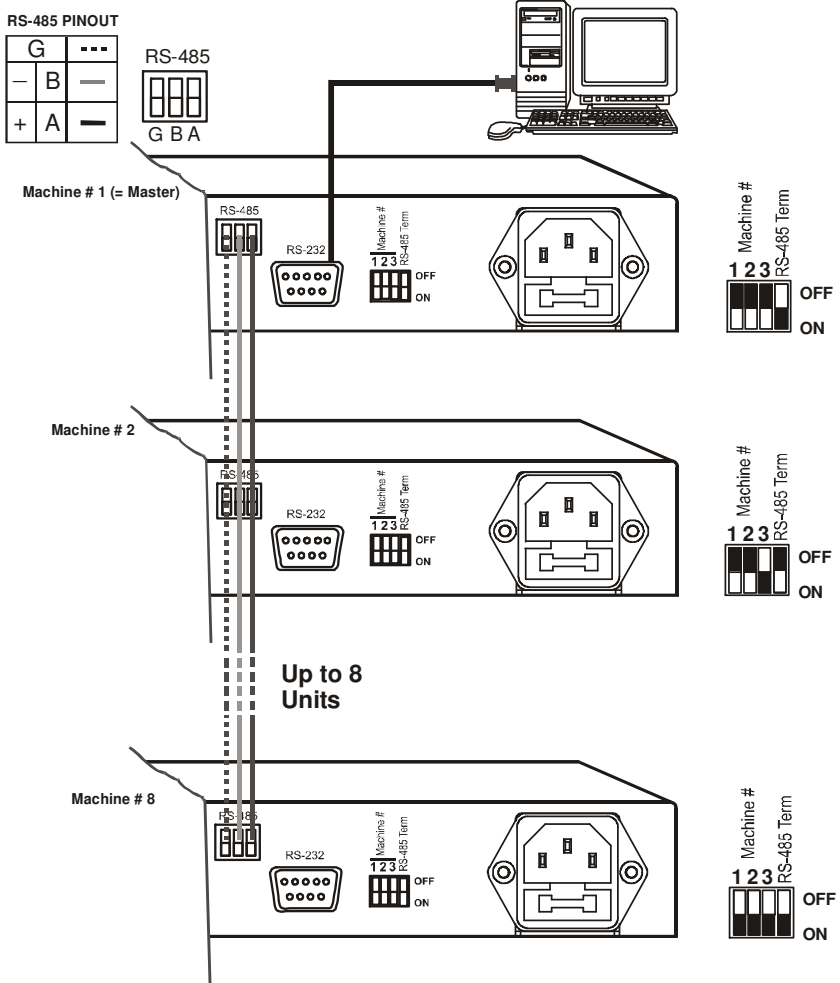

Figure 7: Control Configuration via RS-232 and RS-485

6.4.1 Dipswitch Settings

The **VP-4x4** includes a set of four dipswitches, as Figure 8 and Table 3 define:

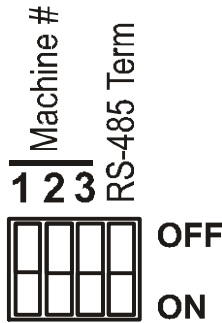

Figure 8: VP-4x4 Dipswitches

Table 3: Dipswitch Settings

DIPS	Function	Description
1, 2, 3	Machine #	Determines the number of the machine in the sequence
4	RS-485 Term	ON for RS-485 line termination ¹ with 120Ω OFF for no RS-485 line termination

The machine # determines the position of a **VP-4x4** unit when cascading units (see section 6.4). Set dipswitches 1, 2 and 3 according to Table 4:

Table 4: Machine # Dipswitch Settings

Machine #	DIP 1	DIP 2	DIP 3
1 ^{Master}	OFF	OFF	OFF
2	OFF	OFF	ON
3	OFF	ON	OFF
4	OFF	ON	ON
5	ON	OFF	OFF
6	ON	OFF	ON
7	ON	ON	OFF
8	ON	ON	ON

¹ When cascading machines, set dipswitch 4 to ON for the first and last units only (otherwise, set dipswitch 4 to OFF)

7 Operating Your Audio Matrix Switcher

You can operate your **VP-4x4** via:

- The front panel buttons
- RS-232 serial commands transmitted by a touch screen system, PC, or other serial controller

7.1 Displaying Unit Characteristics

Figure 9 shows an example of the display immediately after switching on the power, or after resetting the machine (by pressing **SELECTOR IN** buttons 1, 2 and 3 simultaneously for three seconds). The **STATUS VIDEO** 7-segment display shows the number of **IN** and **OUT** ports, and the **STATUS AUDIO** 7-segment display shows the firmware version number and the machine number.

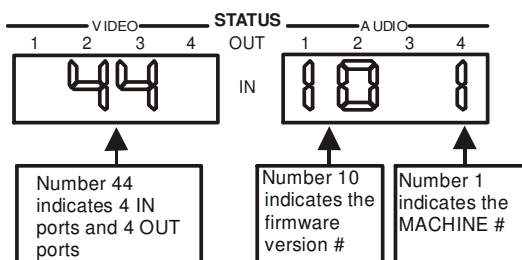

Figure 9: VP-4x4 Unit Characteristics

This display disappears after a few seconds, replaced by the normal display¹.

7.2 Choosing the Audio-Follow-Video or Breakaway Option

You can switch stereo audio signals in one of 2 ways, either:

- Audio-follow-video (AFV), in which all operations and status indicators relate to both the video and the audio channels²; or
- Breakaway, in which video and audio channels switch independently

¹ During normal operation, the **STATUS** display shows which inputs are switched to which outputs, both for video and audio signals

² Audio and video connections are the same

7.2.1 Setting the Audio-Follow-Video Option

To set the Audio-Follow-Video (AFV) option:

1. Press the AFV button.
The AFV button illuminates. The audio will follow the video.
2. If the audio configuration differs from the video configuration, both the Audio IN STATUS 7-segment displays and the AUD button will blink¹, and require reconfiguring for AFV operation.
3. Press the TAKE button to confirm the modification (reconfiguring the audio according to the video).

7.2.2 Setting the Breakaway Option

To set the Breakaway option:

1. Press either the AUD (for audio control only) or the VID (for video control only) button.
2. If the AUD button illuminates all switching operations relate to the Audio section.
3. If the VID button illuminates all switching operations relate to the Video section.

7.3 Switching OUT-IN Combinations

To switch a video/audio input to a video/audio output, do the following:

1. Press an OUT button².
The corresponding Audio and³/or Video IN STATUS 7-segment displays⁴ blink.
2. Press an IN button⁵.
The selected input switches to the selected output.

For example, press the ALL button and then IN button # 2 to connect input # 2 to all the outputs

1 Warning that changes are about to occur in the audio section

2 Either 1, 2, 3, 4 or ALL

3 When the audio-follow-video option is active (refer to section 7.2)

4 Items 8 and 9, respectively, in Figure 1

5 Either 1, 2, 3, 4 or OFF

7.4 Confirming Settings

Choose to work in the AT ONCE or the CONFIRM mode.

In the AT ONCE mode:

- You save time
- Actions require no user confirmation
- Execution is immediate
- No protection is offered against changing an action in error

In the CONFIRM mode:

- You have an optional method to help avoid making a mistake
- Every action requires user confirmation
- Execution is delayed¹ until the user confirms the action
- Protection is offered to prevent erroneous switching
- You can key-in several actions and then confirm them by pressing the TAKE button once, to simultaneously switch all monitors

Pressing an OUT-IN combination when your **VP-4x4** operates in the AT ONCE mode implements the switch immediately. When the **VP-4x4** operates in the CONFIRM mode, press the blinking TAKE button to authorize the switch.

7.4.1 Toggling between the AT ONCE and CONFIRM Modes

To toggle between the AT ONCE and CONFIRM modes, do the following:

1. Press the TAKE button to toggle from the AT ONCE mode² to the CONFIRM mode³.
Actions now require user confirmation and the TAKE button illuminates.
2. Press the illuminated TAKE button to toggle from the CONFIRM mode back to the AT ONCE mode.
Actions no longer require user confirmation and the TAKE button no longer illuminates.

¹ Failure to press the TAKE button within one minute (the Timeout) will abort the action

² The TAKE button does not illuminate

³ The TAKE button illuminates

7.4.2 Confirming a Switching Action

To confirm a switching action (in CONFIRM mode), do the following:

1. Press an OUT-IN combination.
The corresponding AUDIO and VIDEO IN STATUS 7-segment displays¹ blink. The TAKE button also blinks.
2. Press the blinking TAKE button to confirm the action.
The corresponding AUDIO and VIDEO IN STATUS 7-segment displays¹ no longer blink. The TAKE button illuminates.

To confirm several actions (in CONFIRM mode), do the following:

1. Press each OUT-IN combination in sequence.
The corresponding AUDIO and VIDEO IN STATUS 7-segment display¹ blinks. The TAKE button also blinks.
2. Press the blinking TAKE button to confirm all the actions.
The corresponding AUDIO and VIDEO IN STATUS 7-segment displays¹ no longer blink. The TAKE button illuminates.

7.5 Storing/Recalling Input/Output Configurations

You can store and recall² up to eight input/output configurations using the four SELECTOR IN and the four SELECTOR OUT buttons, as Figure 10 illustrates:

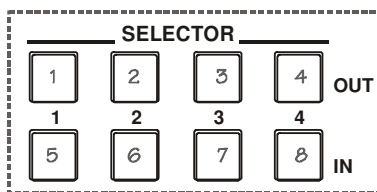

Figure 10: SELECTOR Buttons³

7.5.1 Storing an Input/Output Configuration

To store the current status in memory, do the following:

1. Press the STO button.
The STO button blinks.

¹ Items 8 and 9, respectively, in Figure 1

² The 8 input/output configurations (or setups) also include the relevant audio-follow-video / breakaway option definition

³ The gray numbers (1 to 8) in Figure 10 that illustrate the corresponding store/recall configuration number, are for the purpose of illustration only and do not actually appear on the buttons

2. Press one of the eight SELECTOR buttons.
The memory stores the data at that reference.

7.5.2 Recalling an Input/Output Configuration

To recall an input/output configuration, do the following:

1. Press the RCL button.
The RCL button blinks.
2. Press the appropriate SELECTOR button.
The memory recalls the stored data from that reference.

If you cannot remember which of the eight input/output configurations is the one that you want, set the **VP-4x4** to the CONFIRM mode and manually scan all the input/output configurations until you locate it.

7.5.3 Deleting an Input/Output Configuration

To delete an input/output configuration, do the following:

1. Press the STO and RCL buttons simultaneously.
Both the STO and RCL buttons blink.
2. Press the appropriate SELECTOR button.
This erases that specific input/output configuration from the memory, leaving it empty and available¹.

7.6 Locking the Front Panel

To prevent changing the settings accidentally or tampering with the front panel, lock your **VP-4x4**. Unlocking releases the protection mechanism.

To lock the **VP-4x4**:

- Press the LOCK button for more than 2 seconds
The LOCK button illuminates, freezing the front panel controls. Pressing a button will have no effect, except to cause the LOCK button to blink². Nevertheless, even though the front panel is locked you can still operate your PC control software

To unlock the **VP-4x4**:

- Press the illuminating LOCK button for more than 2 seconds
The **VP-4x4** unlocks and the LOCK button no longer illuminates

¹ Storing a new configuration over a previous configuration (without deleting it first) replaces the previous configuration

² Warning that you need to unlock to regain control via the front panel

8 Technical Specifications

Table 5 includes the technical specifications:

Table 5: Technical Specifications¹ of the VP-4x4 VGA/XGA Audio Matrix Switcher

INPUTS:	4 analog red, green, blue signals - 0.7 Vpp/75Ω, H & V syncs, TTL level on HD15F connectors 4 balanced audio stereo signals, + 4dBm/33K typical, 21 Vpp max. on detachable terminal blocks
OUTPUTS:	4 analog red, green, blue signals - 0.7 Vpp/75Ω, H & V syncs, TTL level on HD15F connectors 4 balanced audio stereo signals, + 4dBm/50Ω typical, 21 Vpp max. on detachable terminal blocks
VIDEO BANDWIDTH (-3dB):	440MHz
AUDIO BANDWIDTH (-3dB):	100kHz
DIFF. GAIN:	0.05%
DIFF. PHASE:	0.13 Deg.
K-FACTOR:	0.05%
VIDEO S/N RATIO:	73dB
AUDIO S/N RATIO:	77dB unweighted
VIDEO CROSSTALK:	-55dB
CONTROL:	Touch switches, RS-232, RS-485
MAX VIDEO OUT:	2.6Vpp
MAX AUDIO OUT:	21Vpp
AUDIO CROSSTALK @ 20kHz:	-81.1dB
AUDIO THD + NOISE:	0.031%
2nd HARMONIC:	0.02%
POWER SOURCE:	230 VAC, 50/60 Hz, (115 VAC, U.S.A.) 12 VA max.
DIMENSIONS:	19-inch (W), 7-inch(D) 1U (H) rack mountable
WEIGHT:	2.7kg. (6 lbs.) approx
ACCESSORIES:	Power cord, Null modem adapter, Windows®-based control software

¹ Specifications are subject to change without notice

9 Table of Hex Codes for Serial Communication

Table 6 lists the Hex values for a single machine (*MACHINE # 1*):

Table 6: VP-4x4 Hex Codes for Switching via RS-232/RS-485

	Switching Video Channels			
	OUT 1	OUT 2	OUT 3	OUT 4
IN 1	01	01	01	01
	81	81	81	81
	81	82	83	84
	81	81	81	81
IN 2	01	01	01	01
	82	82	82	82
	81	82	83	84
	81	81	81	81
IN 3	01	01	01	01
	83	83	83	83
	81	82	83	84
	81	81	81	81
IN 4	01	01	01	01
	84	84	84	84
	81	82	83	84
	81	81	81	81

Table 7 lists the Hex values for switching audio channels via RS-232/RS-485:

Table 7: VP-4x4 Hex Codes for Switching Audio Channels via RS-232/RS-485

	Switching Audio Channels			
	OUT 1	OUT 2	OUT 3	OUT 4
IN 1	02	02	02	02
	81	81	81	81
	81	82	83	84
	81	81	81	81
IN 2	02	02	02	02
	82	82	82	82
	81	82	83	84
	81	81	81	81
IN 3	02	02	02	02
	83	83	83	83
	81	82	83	84
	81	81	81	81
IN 4	02	02	02	02
	84	84	84	84
	81	82	83	84
	81	81	81	81

10 Kramer Protocol 2000¹

The **VP-4x4** is compatible with Kramer's Protocol 2000 (version 0.46) (below). This RS-232/RS-485 communication protocol uses four bytes of information as defined below. For RS-232, a null-modem connection between the machine and controller is used. The default data rate is 9600 baud, with no parity, 8 data bits and 1 stop bit.

Table 8: Protocol Definitions

MSB								LSB
	DESTINATION	INSTRUCTION						
0	D	N5	N4	N3	N2	N1	N0	
7	6	5	4	3	2	1	0	
1st byte								
	INPUT							
1	I6	I5	I4	I3	I2	I1	I0	
7	6	5	4	3	2	1	0	
2nd byte								
	OUTPUT							
1	O6	O5	O4	O3	O2	O1	O0	
7	6	5	4	3	2	1	0	
3rd byte								
	MACHINE NUMBER							
1	OVR	X	M4	M3	M2	M1	M0	
7	6	5	4	3	2	1	0	
4th byte								

1st BYTE: Bit 7 – Defined as 0.

D – “DESTINATION”: 0 - for sending information to the switchers (from the PC);

1 - for sending to the PC (from the switcher).

N5...N0 – “INSTRUCTION”

The function that is to be performed by the switcher(s) is defined by the INSTRUCTION (6 bits). Similarly, if a function is performed via the machine's keyboard, then these bits are set with the INSTRUCTION NO., which was performed. The instruction codes are defined according to the table below (INSTRUCTION NO. is the value to be set for N5...N0).

2nd BYTE: Bit 7 – Defined as 1.

I6...I0 – “INPUT”.

When switching (ie. instruction codes 1 and 2), the INPUT (7 bits) is set as the input number which is to be switched. Similarly, if switching is done via the machine's front-panel, then these bits are set with the INPUT NUMBER which was switched. For other operations, these bits are defined according to the table.

3rd BYTE: Bit 7 – Defined as 1.

O6...O0 – “OUTPUT”.

When switching (ie. instruction codes 1 and 2), the OUTPUT (7 bits) is set as the output number which is to be switched. Similarly, if switching is done via the machine's front-panel, then these bits are set with the OUTPUT NUMBER which was switched. For other operations, these bits are defined according to the table.

4th BYTE: Bit 7 – Defined as 1.

Bit 5 – Don't care.

OVR – Machine number override.

M4...M0 – MACHINE NUMBER.

Used to address machines in a system via their machine numbers. When several machines are controlled from a single serial port, they are usually configured together with each machine having an individual machine number. If the OVR bit is set to 1, then all machine numbers will accept (implement) the command, and only the addressed machine will reply.

¹ You can download our user-friendly “Software for Calculating Hex Codes for Protocol 2000” from the technical support section on our Web site at: <http://www.kramerelectronics.com>

Kramer Protocol 2000

For a single machine controlled via the serial port, always set M4...M0 = 00001, and make sure that the machine itself is configured as MACHINE NUMBER = 1.

Table 9: Instruction Codes for Protocol 2000

Note: All values in the table are decimal, unless otherwise stated.

INSTRUCTION		DEFINITION FOR SPECIFIC INSTRUCTION		NOTE
#	DESCRIPTION	INPUT	OUTPUT	
0	RESET VIDEO	0	0	1
1	SWITCH VIDEO	Set equal to video input which is to be switched (0 = disconnect)	Set equal to video output which is to be switched (0 = to all the outputs)	2, 15
2	SWITCH AUDIO	Set equal to audio input which is to be switched (0 = disconnect)	Set equal to audio output which is to be switched (0 = to all the outputs)	2
3	STORE VIDEO STATUS	Set as SETUP #	0 - to store 1 - to delete	2, 3, 15
4	RECALL VIDEO STATUS	Set as SETUP #	0	2, 3, 15
5	REQUEST STATUS OF A VIDEO OUTPUT	Set as SETUP #	Equal to output number whose status is reqd	4, 3
6	REQUEST STATUS OF AN AUDIO OUTPUT	Set as SETUP #	Equal to output number whose status is reqd	4, 3
7	VIS SOURCE	Set as input # when OUTPUT byte = 6; OR set as output # when OUTPUT byte = 7; OR set as blank period (in steps of 25ms) when OUTPUT byte = 32; OR set = 0, *****	0 - No VIS (immediate) 1 - Input # 1 2 - External digital sync 3 - External analog sync 4 - Dynamic sync 5 - Inter-machine sync 6 - Input # (INPUT byte) 7 - Output # (INPUT byte) 8 - User-defined sync 32 - RGBHV seamless switching 64 - Set for delayed switch 65 - Execute delayed switch 66 - Cancel delayed switch setting	2, 5, 17, 18
8	BREAKAWAY SETTING	0	0 - audio-follow-video 1 - audio breakaway	2
		1	0 - FOLLOW mode 1 - Normal mode	15
9	VIDEO / AUDIO TYPE SETTING	0 - for video	0 - CV 4 - SDI 1 - YC 5 - CV+YC 2 - YUV 6 - VGA scaler 3 - RGBS 7 - DVI	2
		1 - for audio	O0=0 – Unbalanced audio O0=1 – Balanced audio O1=0 – Digital audio O1=1 – Analog audio O4=0, O3=0, O2=0-Mono O4=0, O3=0, O2=1-Stereo	
		2 - for VGA and DVI	1 - 640X480 2 - 800X600 3 - 1024X768	
10	REQUEST VIS SETTING	Set as SETUP #, or set to 126 or 127 to request if machine has this function	0 - VIS source 1 - Input # or output # of source 2 - Vertical sync freq (Hz)	3, 4, 6, 7
11	REQUEST BREAKAWAY SETTING	Set as SETUP #, or set to 126 or 127 to request if machine has this function	0 - Request audio breakaway setting 1 - Request "FOLLOW" setting	3, 4, 6, 15
12	REQUEST VIDEO / AUDIO TYPE SETTING	Set as SETUP #, or set to 126 or 127 to request if machine has this function	0 - for video 1 - for audio 2 - for VGA	3, 4, 6
13	SET HIGHEST MACHINE ADDRESS	0 - for video 1 - for audio	Set equal to highest machine address	2
14	REQUEST HIGHEST MACHINE ADDRESS	0 - for video 1 - for audio	0	4

Kramer Protocol 2000

INSTRUCTION		DEFINITION FOR SPECIFIC INSTRUCTION		NOTE
#	DESCRIPTION	INPUT	OUTPUT	
15	REQUEST WHETHER SETUP IS DEFINED / VALID INPUT IS DETECTED	SETUP # or Input #	0 - for checking if setup is defined 1 - for checking if input is valid	8
16	ERROR / BUSY	For invalid / valid input (i.e. OUTPUT byte = 4 or OUTPUT byte = 5), this byte is set as the input #	0 - error 1 - invalid instruction 2 - out of range 3 - machine busy 4 - invalid input 5 - valid input	9, 25
17	RESERVED	----	----	10
18	RESET AUDIO	0	0	1
19	STORE AUDIO STATUS	Set as SETUP #	0 - to store 1 - to delete	2, 3
20	RECALL AUDIO STATUS	Set as SETUP #	0	2, 3
21	SET VIDEO PARAMETER	Equal to input / output number whose video parameter is to be set (0 = all)	Set as parameter value	2, 11, 24
22	SET AUDIO PARAMETER	Equal to input / output number whose gain is to be set (0 = all)	Set as parameter value	2, 11, 24
23	INCREASE / DECREASE VIDEO PARAMETER	Equal to input / output number whose video parameter is to be increased / decreased (0 = all)	0 - increase video gain 1 - decrease video gain 2 - increase contrast 3 - decrease contrast 4 - increase brightness 5 - decrease brightness 6 - increase color 7 - decrease color 8 - increase hue 9 - decrease hue 16 - increase H-phase 17 - decrease H-phase 18 - increase V-position 19 - decrease V-position	24
24	INCREASE / DECREASE AUDIO PARAMETER	Equal to input / output number whose parameter is to be increased / decreased (0 = all)	0 - increase output 1 - decrease output 2 - increase left output 3 - decrease left output 4 - increase right output 5 - decrease right output 6 - increase input 7 - decrease input 8 - increase left input 9 - decrease left input 10 - increase right input 11 - decrease right input	24
25	REQUEST AUDIO PARAMETER	Equal to input / output number whose parameter is requested	0	6, 24
26	REQUEST VIDEO PARAMETER	Equal to input / output number whose video parameter is requested	0	6, 24
30	LOCK FRONT PANEL	0 - Panel unlocked 1 - Panel locked	0	2
31	REQUEST WHETHER PANEL IS LOCKED	0	0	16
32 to 35	RESERVED	----	----	10
40	DIRECT MEMORY SAVE	Memory address	Data	20

INSTRUCTION		DEFINITION FOR SPECIFIC INSTRUCTION		NOTE
#	DESCRIPTION	INPUT	OUTPUT	
42	AUDIO PARAMETER SETTINGS FOR INSTRUCTIONS 22, 24, 25	INPUT Bit: 10 - 0=input; 1=output 11 - Left 12 - Right	0 - Gain 1 - Bass 2 - Treble 3 - Midrange	24
43	VIDEO PARAMETER SETTINGS FOR INSTRUCTIONS 21, 23, 26	1 - Input 2 - Output	0 - video gain 1 - contrast 2 - brightness 3 - colour 4 - hue 5 - H-phase 6 - V-position	24
56	CHANGE TO ASCII	0	1 - SVS protocol 2 - Generic protocol	19
57	SET AUTO-SAVE	13 - no save 14 - auto-save	0	12, 2
58	EXECUTE LOADED DATA	Set as 0, or as SETUP #.	1-Take 2-Cancel	22, 3
59	LOAD VIDEO DATA	Set equal to video input (0 = disconnect) ----- (127 = load SETUP #)	Set equal to video output (0 = to all the outputs) ----- or SETUP #	22, 23
60	LOAD AUDIO DATA	Set equal to audio input (0 = disconnect) ----- (127 = load SETUP #)	Set equal to audio output (0 = to all the outputs) ----- or SETUP #	22, 23
61	IDENTIFY MACHINE	1 - video machine name 2 - audio machine name 3 - video software version 4 - audio software version 5 - RS422 controller name 6 - RS422 controller version 7 - remote control name 8 - remote software version 9 - Protocol 2000 revision	0 - Request first 4 digits 1 - Request first suffix 2 - Request second suffix 3 - Request third suffix 10 - Request first prefix 11 - Request second prefix 12 - Request third prefix	13
62	DEFINE MACHINE	1 - number of inputs 2 - number of outputs 3 - number of setups	1 - for video 2 - for audio 3 - for SDI 4 - for remote panel 5 - for RS-422 controller	14
63	EXTENDED DATA	7 MSBs for INPUT data	7 MSBs for OUTPUT data	20

NOTES on the above table:

NOTE 1 - When the master switcher is reset, (e.g. when it is turned on), the reset code is sent to the PC. If this code is sent to the switchers, it will reset according to the present power-down settings.

NOTE 2 - These are bi-directional definitions. That is, if the switcher receives the code, it will perform the instruction; and if the instruction is performed (due to a keystroke operation on the front panel), then these codes are sent. For example, if the HEX code

01 85 88 83

was sent from the PC, then the switcher (machine 3) will switch input 5 to output 8. If the user switched input 1 to output 7 via the front panel keypad, then the switcher will send HEX codes:

41 81 87 83

to the PC.

When the PC sends one of the commands in this group to the switcher, then, if the instruction is valid, the switcher replies by sending to the PC the same four bytes that it was sent (except for the first byte, where the DESTINATION bit is set high).

NOTE 3 - SETUP # 0 is the present setting. SETUP # 1 and higher are the settings saved in the switcher's memory, (i.e. those used for Store and Recall).

NOTE 4 - The reply to a "REQUEST" instruction is as follows: the same instruction and INPUT codes as were sent are returned, and the OUTPUT is assigned the value of the requested parameter. The replies to instructions 10 and 11 are as per the definitions in instructions 7 and 8 respectively. For example, if the present status of machine number 5 is breakout setting, then the reply to the HEX code

0B 80 80 85

would be HEX codes

4B 80 81 85

NOTE 5 – For the OUTPUT byte set as 6, the VIS source is the input selected using the OUTPUT byte. Similarly, for the OUTPUT byte set as 7, the VIS source is the output selected using the OUTPUT byte. Note also, that on some machines the sync source is not software selectable, but is selected using switches, jumpers, etc!

NOTE 6 – If INPUT is set to 127 for these instructions, then, if the function is defined on this machine, it replies with OUTPUT=1. If the function is not defined, then the machine replies with OUTPUT=0, or with an error (invalid instruction code).

If the INPUT is set to 126 for these instructions, then, if possible, the machine will return the current setting of this function, even for the case that the function is not defined. For example, for a video switcher which always switches during the VIS of input #1, (and its VIS setting cannot be programmed otherwise), the reply to the HEX code

0A FE 80 81 (ie. request VIS setting, with INPUT set as 126_{dec})

would be HEX codes

4A FE 81 81 (ie. VIS setting = 1, which is defined as VIS from input #1).

NOTE 7 – Setting OUTPUT to 0 will return the VIS source setting as defined in instruction #7. Setting to 1 will return the input # or output # of the sync source (for the case where the VIS source is set as 6 or as 7 in instruction #7). Setting to 2 returns the vertical sync frequency (0 for no input sync, 50 for PAL, 60 for NTSC, 127 for error).

NOTE 8 - The reply is as in TYPE 3 above, except that here the OUTPUT is assigned with the value 0 if the setup is not defined / no valid input is detected; or 1 if it is defined / valid input is detected.

NOTE 9 - An error code is returned to the PC if an invalid instruction code was sent to the switcher, or if a parameter associated with the instruction is out of range (e.g. trying to save to a setup greater than the highest one, or trying to switch an input or output greater than the highest one defined). This code is also returned to the PC if an RS-232 instruction is sent while the machine is being programmed via the front panel. Reception of this code by the switcher is not valid.

NOTE 10 – This code is reserved for internal use.

NOTE 11 – For machines where the video and / or audio gain is programmable.

NOTE 12 - Under normal conditions, the machine's present status is saved each time a change is made. The "power-down" save (auto-save) may be disabled using this code. Note that whenever the machine is turned on, the auto-save function is set.

NOTE 13 - This is a request to identify the switcher/s in the system. If the OUTPUT is set as 0, and the INPUT is set as 1, 2, 5 or 7, the machine will send its name. The reply is the decimal value of the INPUT and OUTPUT. For example, for a 2216, the reply to the request to send the audio machine name would be (HEX codes):

7D 96 90 81 (i.e. 128_{dec}+ 22_{dec} for 2nd byte, and 128_{dec}+ 16_{dec} for 3rd byte).

If the request for identification is sent with the INPUT set as 3 or 4, the appropriate machine will send its software version number. Again, the reply would be the decimal value of the INPUT and OUTPUT - the INPUT representing the number in front of the decimal point, and the OUTPUT representing the number after it. For example, for version 3.5, the reply to the request to send the version number would be (HEX codes):

7D 83 85 81 (i.e. 128_{dec}+ 3_{dec} for 2nd byte, 128_{dec}+ 5_{dec} for 3rd byte).

If the OUTPUT is set as 1, then the ASCII coding of the lettering following the machine's name is sent. For example, for the VS-7588YC, the reply to the request to send the first suffix would be (HEX codes):

7D D9 C3 81 (i.e. 128_{dec}+ ASCII for "Y"; 128_{dec}+ ASCII for "C").

NOTE 14 - The number of inputs and outputs refers to the specific machine which is being addressed, *not* to the system. For example, if six 16X16 matrices are configured to make a 48X32 system (48 inputs, 32 outputs), the reply to the HEX code

3E 82 81 82 (ie. request the number of outputs)

would be HEX codes

7E 82 90 82

ie. 16 outputs

NOTE 15 – When the OVR bit (4th byte) is set, then the "video" commands have universal meaning. For example, instruction 1 (SWITCH VIDEO) will cause all units (including audio, data, etc.) to switch. Similarly, if a machine is in "FOLLOW" mode, it will perform any "video" instruction.

NOTE 16 - The reply to the "REQUEST WHETHER PANEL IS LOCKED" is as in NOTE 4 above, except that here the OUTPUT is assigned with the value 0 if the panel is unlocked, or 1 if it is locked.

NOTE 17 – For clean switching of RGBHV video, the "seamless switching" option may be used. The blanking period for the transition of the RGB sources may be set in this case, in steps of 25 milliseconds.

For example, to set for 350ms blanking time (14 steps), send HEX codes

07 8E A0 81

NOTE 18 – Delayed execution allows switching after a delay dictated by RS-232. To do this, the user sends instruction 7 with the “Set for delayed switch” option (64_{dec}) before sending the switch command (instruction 1) or pressing via front panel. The switch is not executed (unless timed-out) until the “Execute delayed switch” code is sent, or the “Set for delayed switch” code is sent again. (The mode is automatically cancelled after implementation of the switch if the “execute” command is used).

For example, to connect input 4 to output 3 after a delay, send HEX codes
 07 80 C0 81 (set for delayed switch)
 01 84 83 81 (switch code)
 then, after the required delay, send HEX codes
 07 80 C1 81 (execute delayed switch)
 to implement the switch.

NOTE 19 – After this instruction is sent, the unit will respond to the ASCII command set defined by the OUTPUT byte. The ASCII command to operate with the HEX command set must be sent in order to return to working with HEX codes.

NOTE 20 – When data (ie. the INPUT and/or OUTPUT bytes) of more than 7 bits is required, this instruction is sent before sending the instruction needing the additional bits. The data in this instruction then becomes the Most Significant Bits of that next instruction. For example, to set the audio gain (instruction 22) of output 3 to 681_{dec} (2A9_{hex}), you would first send HEX codes

 3F 80 85 81
 and then send HEX codes
 16 83 A9 81.

To set the audio gain of output 6 to 10013_{dec} (271D_{hex}), first send HEX codes

 3F 80 CE 81
 followed by HEX codes
 16 86 9D 81.

NOTE 21 – To store data in the non-volatile memory of the unit, eg. the EEPROM for saving SETUPS. The EEPROM address is sent using the INPUT byte, and the data to be stored is sent using the OUTPUT byte. To use this instruction, it is necessary to understand the memory map, and memory structure of the particular machine.

NOTE 22 – Instruction 59 and instruction 60 load data for sending to the crosspoint switcher (or for storing in a SETUP), ie. the data is “lined-up” to be executed later. Instruction 58 executes the loaded data.

NOTE 23 – If the INPUT byte is set as 127_{dec}, then the data stored in a SETUP is loaded. The SETUP # is in the OUTPUT byte.

NOTE 24 – Further information needed in instructions 21, 22, 25 and 26, is sent using instruction 42 – which is sent prior to the instruction. For example, to request the audio gain value of right input # 9, send hex codes

 2A 84 80 81
 and then send HEX codes
 19 89 81 81.

NOTE 25 – For units which detect the validity of the video inputs, Instruction 16 will be sent whenever the unit detects a change in the state of an input (in real-time).

For example, if input 3 is detected as invalid, the unit will send the HEX codes

 10 83 84 81

If input 7 is detected as valid, then the unit will send HEX codes

 10 87 85 81.

LIMITED WARRANTY

Kramer Electronics (hereafter *Kramer*) warrants this product free from defects in material and workmanship under the following terms.

HOW LONG IS THE WARRANTY

Labor and parts are warranted for seven years from the date of the first customer purchase.

WHO IS PROTECTED?

Only the first purchase customer may enforce this warranty.

WHAT IS COVERED AND WHAT IS NOT COVERED

Except as below, this warranty covers all defects in material or workmanship in this product. The following are not covered by the warranty:

1. Any product which is not distributed by Kramer, or which is not purchased from an authorized Kramer dealer. If you are uncertain as to whether a dealer is authorized, please contact Kramer at one of the agents listed in the web site www.kramerelectronics.com.
2. Any product, on which the serial number has been defaced, modified or removed.
3. Damage, deterioration or malfunction resulting from:
 - i) Accident, misuse, abuse, neglect, fire, water, lightning or other acts of nature
 - ii) Product modification, or failure to follow instructions supplied with the product
 - iii) Repair or attempted repair by anyone not authorized by Kramer
 - iv) Any shipment of the product (claims must be presented to the carrier)
 - v) Removal or installation of the product
 - vi) Any other cause, which does not relate to a product defect
 - vii) Cartons, equipment enclosures, cables or accessories used in conjunction with the product

WHAT WE WILL PAY FOR AND WHAT WE WILL NOT PAY FOR

We will pay labor and material expenses for covered items. We will not pay for the following:

1. Removal or installations charges.
2. Costs of initial technical adjustments (set-up), including adjustment of user controls or programming. These costs are the responsibility of the Kramer dealer from whom the product was purchased.
3. Shipping charges.

HOW YOU CAN GET WARRANTY SERVICE

1. To obtain service on you product, you must take or ship it prepaid to any authorized Kramer service center.
2. Whenever warranty service is required, the original dated invoice (or a copy) must be presented as proof of warranty coverage, and should be included in any shipment of the product. Please also include in any mailing a contact name, company, address, and a description of the problem(s).
3. For the name of the nearest Kramer authorized service center, consult your authorized dealer.

LIMITATION OF IMPLIED WARRANTIES

All implied warranties, including warranties of merchantability and fitness for a particular purpose, are limited in duration to the length of this warranty.

EXCLUSION OF DAMAGES

The liability of Kramer for any effective products is limited to the repair or replacement of the product at our option. Kramer shall not be liable for:

1. Damage to other property caused by defects in this product, damages based upon inconvenience, loss of use of the product, loss of time, commercial loss; or:
2. Any other damages, whether incidental, consequential or otherwise. Some countries may not allow limitations on how long an implied warranty lasts and/or do not allow the exclusion or limitation of incidental or consequential damages, so the above limitations and exclusions may not apply to you.

This warranty gives you specific legal rights, and you may also have other rights, which vary from place to place.

NOTE: All products returned to Kramer for service must have prior approval. This may be obtained from your dealer. This equipment has been tested to determine compliance with the requirements of:

- EN-50081: "Electromagnetic compatibility (EMC);
generic emission standard.
Part 1: Residential, commercial and light industry"
- EN-50082: "Electromagnetic compatibility (EMC) generic immunity standard.
Part 1: Residential, commercial and light industry environment".
- CFR-47: FCC Rules and Regulations:
Part 15: "Radio frequency devices
Subpart B – Unintentional radiators"

CAUTION!

- ☒ Servicing the machines can only be done by an authorized Kramer technician. Any user who makes changes or modifications to the unit without the expressed approval of the manufacturer will void user authority to operate the equipment.
- ☒ Use the supplied DC power supply to feed power to the machine.
- ☒ Please use recommended interconnection cables to connect the machine to other components.





For the latest information on our products and a list of Kramer distributors, visit our Web site: www.kramerelectronics.com, where updates to this user manual may be found. We welcome your questions, comments and feedback.



Caution

Safety Warning:

Disconnect the unit from the power supply before opening/servicing.



Kramer Electronics, Ltd.

Web site: www.kramerelectronics.com

E-mail: info@kramerel.com

P/N: 2900-002013 REV 3